

Version
01.00April
2004

Digital Video Measurement System R&S® DVM 400

Monitoring, analysis, recording and generation of MPEG-2 transport streams

- ◆ Transport stream monitoring
 - Monitoring of all TR 101 290 first, second and third priority parameters (except buffer)
 - Data rate monitoring
 - Single frequency network monitoring
 - Data rates up to 214 Mbit/s
 - Event-controlled transport stream capture function
 - User-definable alarm relays
 - Flexible definition of monitoring parameters
- ◆ Transport stream analysis
 - Data rates
 - PCR and PTS analysis
 - Table/packet interpreter
 - Data broadcast analysis
- ◆ Transport stream generation, recording and replaying
 - Bit rates up to 214 Mbit/s
 - Memory up to 160 Gbyte
 - Extensive test signal library
 - Transport stream generation software
- ◆ Operating features
 - Event Navigator
 - Assistant
- ◆ Large colour display
- ◆ USB interfaces on front and rear panels
- ◆ Ethernet interface (100 Mbit/s)
- ◆ Simple remote control
- ◆ System integration via SNMP for monitoring applications
- ◆ Flexible option management

ROHDE & SCHWARZ

General

The R&S®DVM 400 is a highly compact, portable MPEG-2 platform that offers a wealth of test, analysis and monitoring functions for digital TV. Users require neither a laptop nor an external monitor to operate the system since it comes equipped with an integrated, high-resolution colour display. The system is operated by means of its keys and rotary knob, or via the supplied USB mouse. An external monitor and keyboard can be connected. Versatile options ensure that customer requirements are optimally satisfied. Functions can usually be added simply by installing a software key.

The R&S®DVM 400 includes a powerful computer platform with various interfaces and space for three plug-in cards. A broadband recorder and generator board can be installed in the first slot. A fast analyzer board as is used in other systems of the R&S®DVM

family is available for the second slot. This board allows parallel monitoring of up to four transport streams. Since both boards function independently of each other, the R&S®DVM 400 can be configured either as a pure recorder and generator or as a pure analyzer. If both boards are installed, special features are available. For example, a recorded signal can be sent directly within the system to the analyzer board for later analysis. Or, if a signal is monitored, the analyzer board can directly trigger the recorder and generator board to perform event-driven recording.

Both boards support a variety of functions, some of which are optionally available. The analyzer board allows not only transport stream monitoring, but also the analysis of data rates, PCR and PTS values, the interpretation of tables and packets plus the analysis of diverse data services.

Various test signals are available for the recorder and generator board. By using the Stream Combiner™ software, users can generate their own transport streams on the R&S®DVM 400.

Like the R&S®DVM 100, the R&S®DVM 400 can be expanded by the R&S®DVM 120 to monitor more than four transport streams; parallel monitoring of up to 20 transport streams is thus possible via the GUI of the R&S®DVM 400 (two R&S®DVM 120 plus options are required).

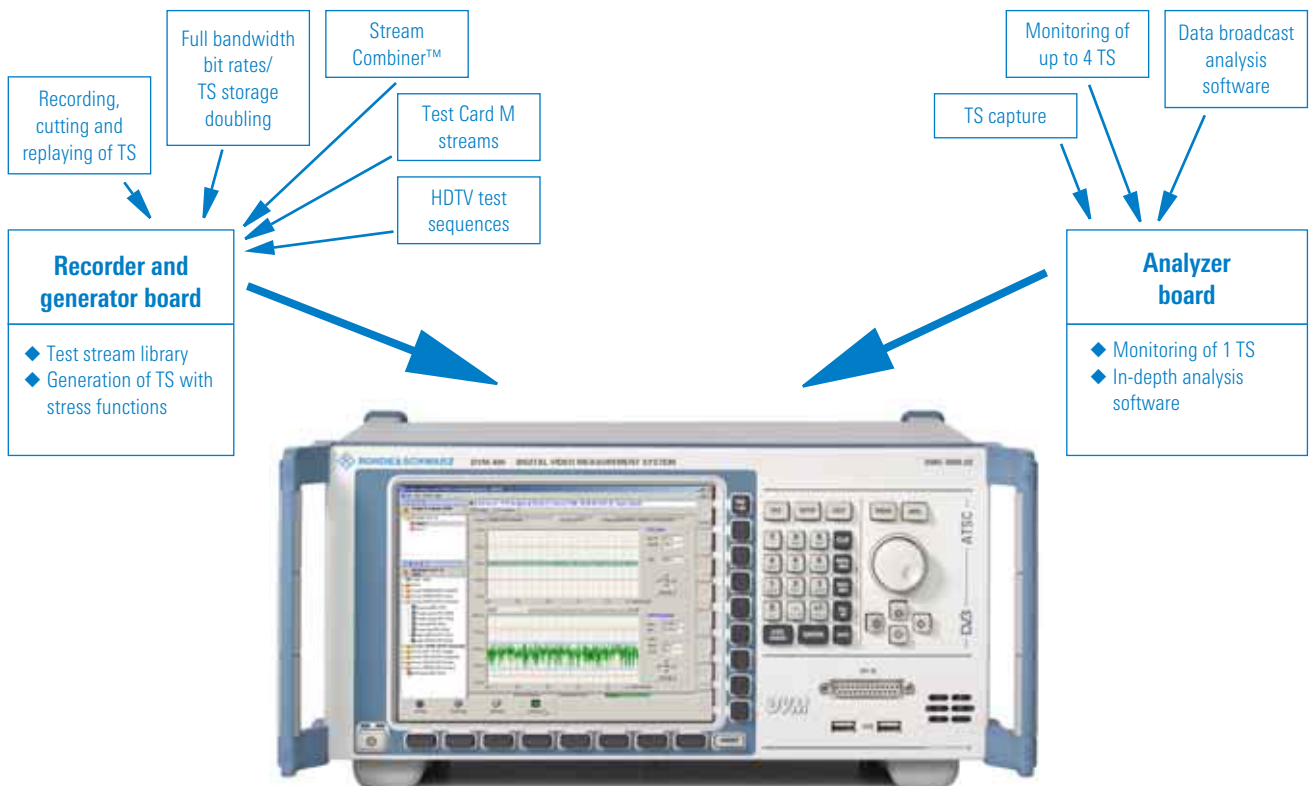

The R&S®DVM 400 functions and options

Monitoring and analysis functions

The figure below shows a block diagram of the analyzer board that is used for the monitoring and analysis functions of the R&S®DVM 400.

Up to four transport streams can be monitored in parallel. One transport stream can be monitored with the analyzer option, another three with one R&S®DVM-K1 option each. In addition to the monitoring functions, numerous analysis functions are available. Analysis can be performed on one of the transport streams at the same time it is being monitored.

Monitoring functions

Transport streams are monitored in accordance with Measurement Guidelines TR 101 290. Well over 100 parameters are monitored on each transport stream, including:

- ◆ All first, second and third priority parameters (with the exception of 3.3, buffer)
- ◆ Bit rates of all transport stream elements (different calculation methods according to TR 101 290 can be selected (MGB1, MGB2 and MGB5 with $\tau = 5$ s))
- ◆ Availability and contents of the megafame initialization packet (MIP), used in single frequency networks (SFN)
- ◆ Modification of conditional access information
- ◆ Transport stream modifications (TSID, addition or omission of elements, etc)

The limit values of all measurement parameters can be set. Individual parameters can be excluded from monitoring so that no unnecessary messages are generated for known or accepted errors.

To obtain a straightforward result display, the user assigns each measurement parameter to one of the three classes below:

- ◆ Alarm
- ◆ Warning
- ◆ Information

If an (error) event is detected, it is displayed along with its associated class. All events are compiled in a report that can fast and easily be sorted and filtered according to diverse criteria. Moreover, there is an error counter for the individual parameters, providing a quick summary of the frequency of individual errors. The data and table refresh rates are clearly presented by means of graphical displays. The use of symbols to indicate different classes of errors makes it possible to quickly determine the current status.

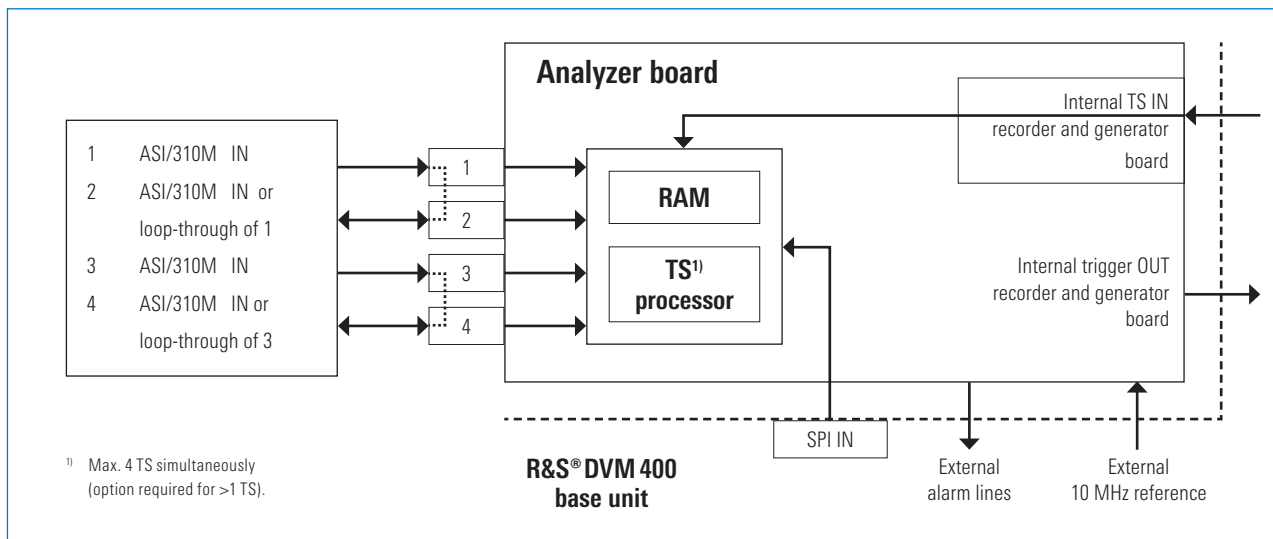

Analyzer board

Event navigator

As a special feature, the R&S® DVM 400 supports filter functions for the report entries which can be easily selected by clicking the right mouse button. It is thus possible to quickly detect

- ◆ All entries for a PID (e.g. all entries for PID 100 (e.g. video))
- ◆ All entries of the same type (e.g. all entries for an incorrect PMT repetition period)
- ◆ All entries for a PID of the same type

Moreover, all entries can be filtered according to their classification (alarm, warning and information).

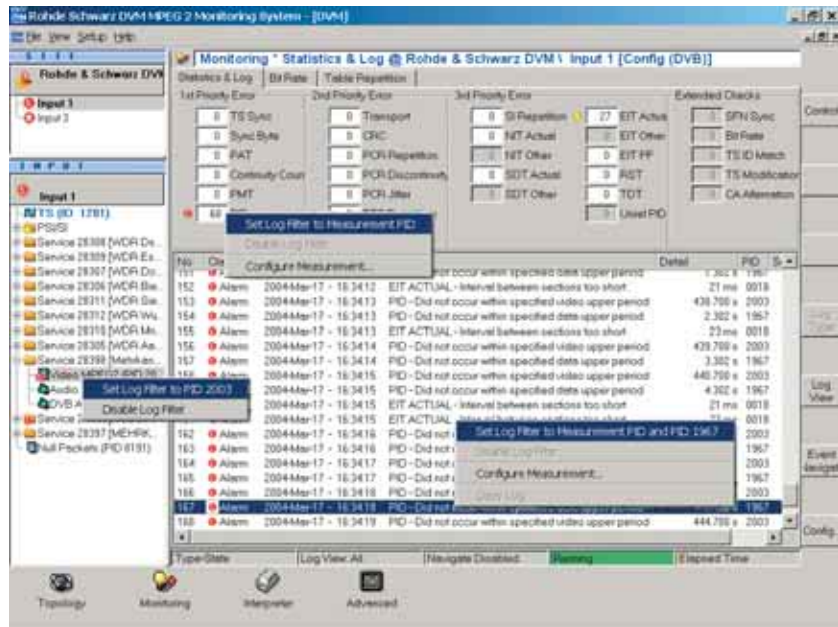

Application example for the event navigator

Analysis functions

Each analysis function can be performed at the same time transport streams are being monitored.

In-depth analysis

PCR jitter: For comprehensive measurement of PCR jitter; selection of one of the two measurements “Overall” or “Accuracy”; setting of the filters used (MGF1 to MGF3) also for monitoring; measurement and filter characteristics as defined in TR 101 290.

PCR distance: Graphical representation of the distance between individual PCR values of a program.

PTS/PCR difference: Graphical representation of the difference between PTS and PCR.

PTS distance: Graphical representation of the distance between individual PTS values of a program.

All measured PCR and PTS values are displayed as traces. Up to one hour of data can be displayed. Zooming within the display is no problem. The figure on the right shows an example of a PCR measurement.

SI/PSI table interpreter: Detects a corresponding section in the TS and interprets its contents.

TS packet interpreter: Displays a transport stream packet in hex format and simultaneously as an interpreted list of contents for the header and adaptation field.

PES header interpreter: Lists all header elements of a selected PES and interprets their contents.

Header map: Provides an overview of the packet distribution of individual elementary streams; displays the first four bytes of each transport stream packet in hex format.

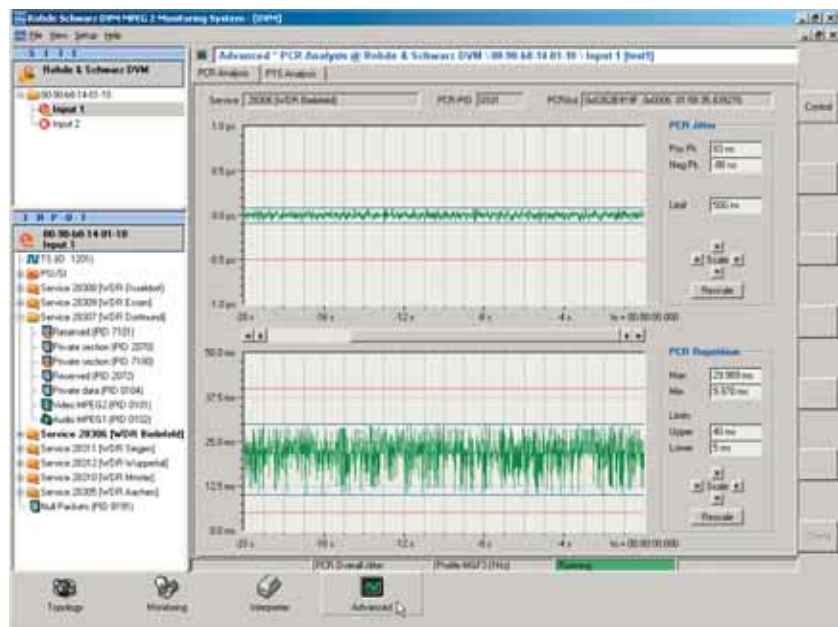

PCR measurement

Data broadcast analysis

A wide scope of analysis functions is available for data broadcast applications. The R&S®DVM 400-B1 base option alone provides the following functionalities.

All transmission techniques and related applications listed below are recognized and entered in the transport stream elements list under the appropriate designation:

- ◆ DVB object carousel, e.g. for downloading of MHP applications
- ◆ DVB data carousel, e.g. for system software updates (SSU)
- ◆ Multi-protocol encapsulation (MPE), e.g. for IP data transmission
- ◆ Data streaming, e.g. for teletext, subtitles, VPS, WSS and transmission of personal data
- ◆ Data piping, e.g. for transmission of personal data

The following tables are also listed:

- ◆ Application information table AIT (MHP)
- ◆ IP/MAC notification table INT (IP data via MPE)
- ◆ System software update notification table UNT (SSU)

The bit rates of a data service can also be measured by means of the associated PID.

In-depth analysis functions:

- ◆ Interpretation of related tables (AIT, INT and UNT)
- ◆ Interpretation of PES headers (data streaming)
- ◆ Interpretation of TS packets (all profiles)

The data broadcast analysis option significantly enhances the scope of functionalities:

Another view can be selected in the GUI. The corresponding section is highlighted in red in the figure below.

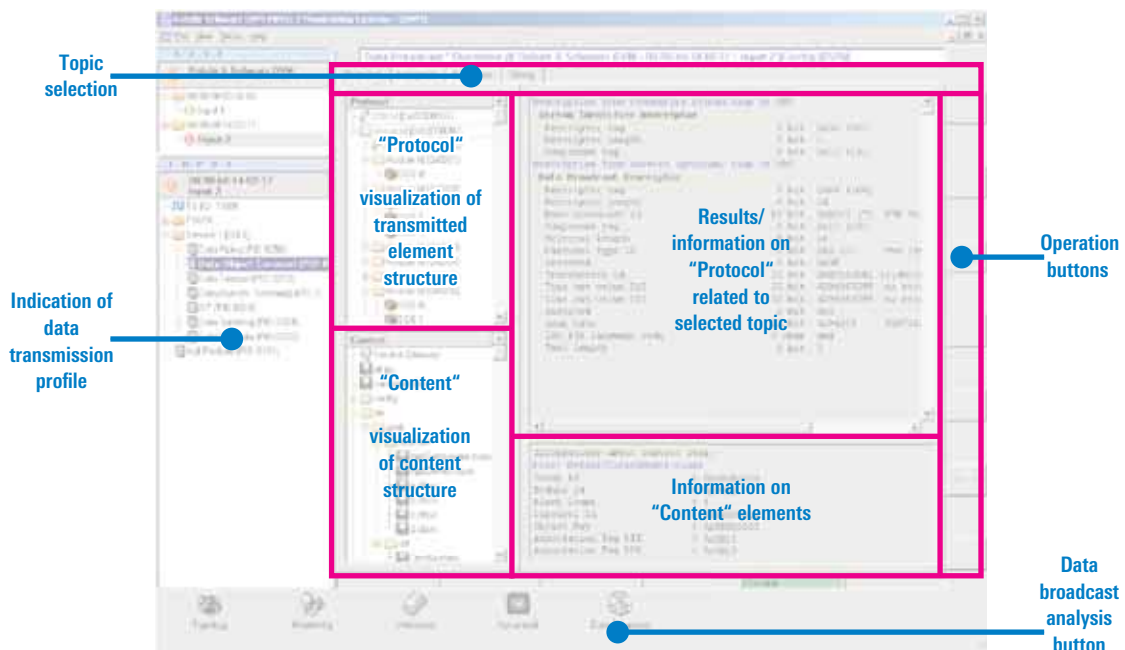

Data broadcast analysis view

The two views "Protocol" and "Content" are especially useful for more complex data transmission methods such as MPE and object and data carousel. The figure on the right shows an example of an object carousel.

These two views have the following functions:

- ◆ "Protocol": displays the transmission element structure
 Example: data/object carousel: DSI, DIIs, DDBs organized in groups and modules
 Example: IP data via MPE: number of sections per MAC address

- ◆ "Content": displays the content structure
 Example: IP data via MPE: MAC addresses found
 Example: object carousel: service gateway, directories, subdirectories, files, references to streams and events

A separate section provides detailed information on the "Content" elements (e.g. related transmission elements), see page 5.

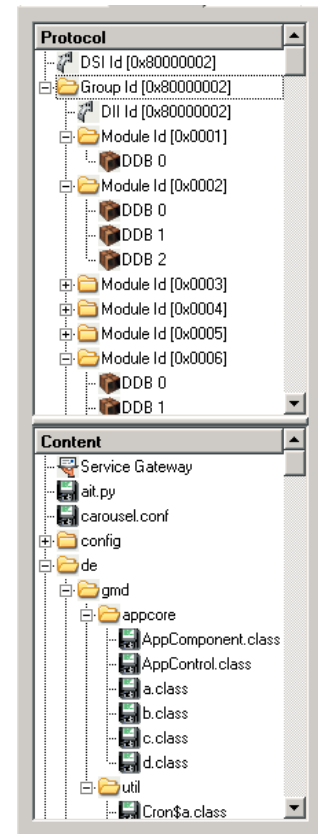

"Protocol" and "Content" display

The following table provides an overview of all available measurements.

	Data piping	Data streaming	MPE	Data carousel	Object carousel
Overview	display of used descriptors and name of tables containing the descriptors				
Interpreter	TS header	PES header	section	section (DSI, DII and DDB header)	
Raw data	TS packet contents	PES packet contents	section contents	DDB section contents	
Timing measurements	<ul style="list-style-type: none"> – ES bit rate – repetition time of payload unit start indicators 	<ul style="list-style-type: none"> – PES bit rate – repetition time of PES header 	<ul style="list-style-type: none"> – bit rate of selected section – repetition time of selected section 	<ul style="list-style-type: none"> – bit rate of selected module, DSI, DII section – repetition time of selected DII, DSI section – loading time of selected module 	

Overview of data broadcast measurements

Assistant

This powerful feature makes the use of the different analysis tools highly effective and easy. Once a transport stream element has been selected, the assistant suggests all analyses and measurement result views that are useful for this element, allowing fast and detailed analysis especially when an error has been detected. The assistant is ideal for less experienced users because it enables them to easily obtain correct measurement results.

TS capture function

This option (R&S®DVM-K2) makes it possible to continuously buffer up to 384 Mbyte¹⁾ of transport stream data in RAM. An event can trigger backup of transport stream data to the system hard disk. This event may be an error detected by the analyzer board or when the user starts recording. This function can be configured in such a way that it waits for a new event once the data has been saved. The stored files are automatically numbered.

This function can also be started for all four transport streams of an analyzer board simultaneously. In this case, 96 Mbyte are available for each transport stream.

The R&S®DVM-K2 option is designed specifically for storing incorrect transport stream sections during analysis or transport stream monitoring. If a large amount of data is involved, the recorder and generator option can be used to record and replay it.

Recorder and generator functions

The figure below shows a block diagram of the recorder and generator board used to record, replay and generate transport streams.

Generation of seamless and endless transport streams

The recorder and generator board allows the generation of endless and seamless transport streams. For this purpose, the TS generator base option contains an extensive collection of transport streams in the Rohde & Schwarz GTS format.

The transport streams generated from the RAM meet all requirements specified in the section "How to generate a transport stream in a seamless endless loop" (page 9). The following characteristics are additionally provided:

- ◆ Jitter of the PCR values (waveform, frequency and amplitude can be set)
- ◆ Selectable data rate (up to 214 Mbit/s by inserting null packets)
- ◆ Transport stream generation in GTS format with user-specific contents (both elementary stream contents as well as PSI/SI/PSIP contents (option Stream Combiner™, R&S®DVG-B1))

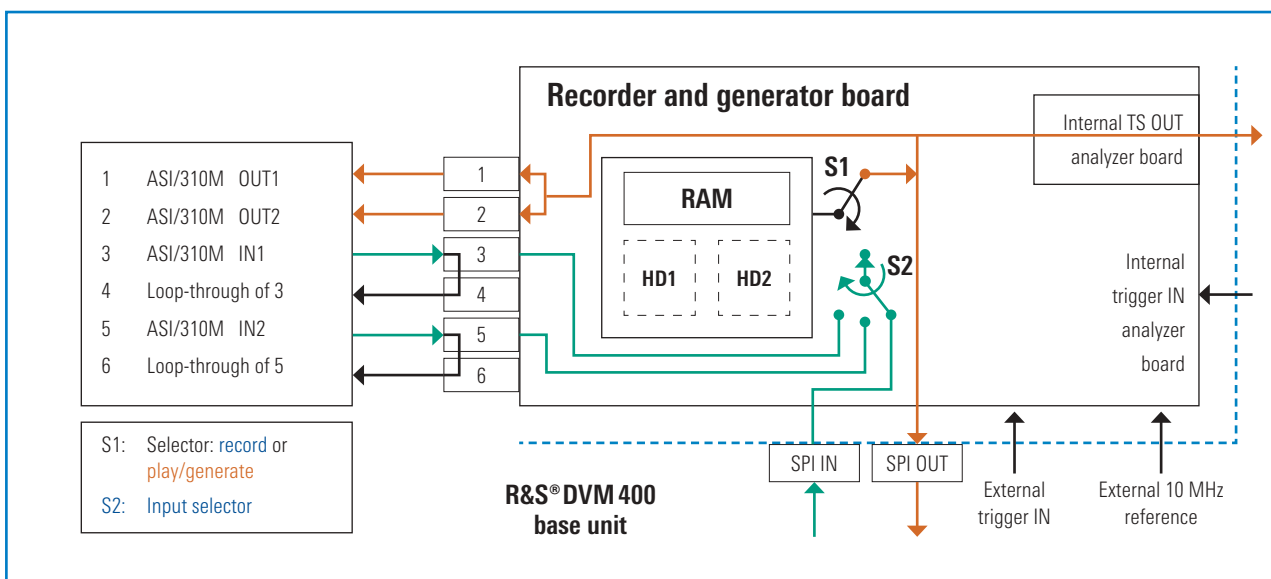

Recorder and generator board

¹⁾ Scheduled for systems delivered as of May 2004 (systems delivered prior to this date feature 128 Mbyte (32 Mbyte with four transport streams)); expansion possible through Rohde & Schwarz Service.

Test signals

The TS generator option comes with a variety of different preconfigured MPEG-2 transport streams that are compliant with the ATSC and DVB standards and can be accessed at a keystroke.

These transport streams are comprised of several elementary streams and contain video, audio and other data (e.g. teletext or PRBS). Video streams with different data rates, formats, frequencies and contents are available.

The signal set comprises sequences with moving picture contents as well as static test patterns. The test patterns include colour bars, zone plate, CCIR17/18/331, ITS1 to ITS4, etc, and the Rohde & Schwarz codec test pattern.

Due to integrated test lines in the upper and lower picture area of this test pattern, the codec signal can be utilized

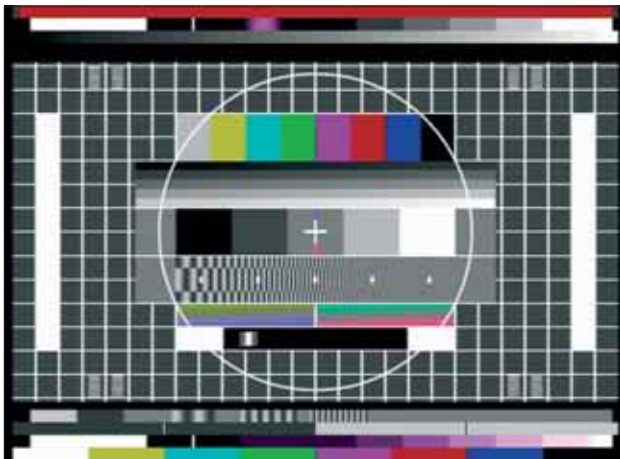

Sample signal: universal 4:3 Rohde & Schwarz codec test pattern

to measure the analog outputs of a set-top box (or IRDs) within a few seconds by using a suitable video analyzer such as the R&S®VSA.

In addition, integrated moving picture elements allow the function of the decoder to be checked visually for any problems. Audio data streams with different sampling rates, encoded according to MPEG-1 layer 2 or Dolby AC-3, contain the accompanying sound

for the video sequences as well as special audio test signals. Of course, the transport streams include all program information, service and system tables (PSIP or SI) required by MPEG-2 and ATSC or DVB as stipulated by the selected standard.

Further options enable HDTV signals and other special test signals to be added to this large collection (see HDTV and Test Card M).

HDTV: The R&S® DV-HDTV option provides an extensive transport stream library containing high-resolution video signals. To generate individual transport streams, this option also includes these video signals in the form of elementary streams. The transport stream data is already stored in the base unit. The function can be enabled by installing a software key. A separate data sheet is available for this option (PD 0757.6979).

Test Card M:

The option R&S® DV-TCM supports the replay of a special collection of transport streams developed by the company Snell & Wilcox and referred to as Test Card M. The transport stream data is already

stored in the base unit. The function can be enabled by installing a software key. A separate data sheet is available for this option (PD 0757.7369).

Recording

Transport streams can be recorded at data rates up to 214 Mbit/s. Exchanging transport streams with other systems is no problem since the stored files contain the transport stream packets in consecutive order and without additional headers.

As a special SPI feature, the recorder and generator board also allows interface-specific data to be recorded simultaneously with transport stream data (8 bits). It records the bits for signalling the start of the packet (PSYNC) and for the validity of the data (DVALID), thus storing a total of 10 bits for 8 data bits. Since recording is transparent, also non-DTV-compliant signals and even signals of other applications can be recorded via the interfaces.

The recording of all signals can be controlled via the external trigger input of the R&S® DVM 400 base unit or the analyzer board. For this purpose, the applied signal is continuously buffered. If a trigger event occurs, the signal sections both following the event (post-trigger) and preceding the event (pretrigger) can be stored. The length of the post- and pretrigger can be set. It is thus possible to determine where in the stored signal the event is located. This function is particularly important for error analysis.

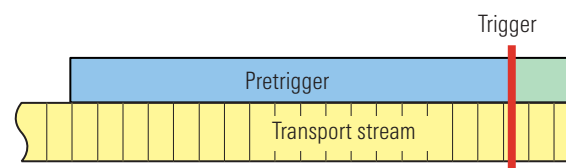

The length of the pre- and post-trigger can be set on the R&S® DVM

Replay of recorded signals

Replayed signals are applied to all external transport stream interfaces simultaneously (ASI/310M OUT 1, 2 and SPI OUT). Signals 10 bits in width can be replayed only via the SPI interface. For optional analysis, the transport stream signals are internally played to the analyzer board.

The signals are replayed in an endless loop in such a way that the transition from the end to the beginning of the recording always coincides with the packet. Correct decoding of the video and audio sequences in the replayed transport stream is ensured only if the original data rate of the recording is used. For this reason, the data rate of transport streams is automatically determined on the basis of the present PCR values. Irrespective of this automatic recognition, the data rate can also be set by the user (up to 214 Mbit/s). Furthermore, the interfaces can be configured for playback. The user can thus choose between the "packet" and "continuous" operating modes for the ASI interface. This feature is especially crucial for router testing.

For the SPI interface, signalling can be set via the "data valid" circuit. This flexibility allows versatile tests to be performed and offers maximum compatibility with other instruments.

A special feature is the packet-exact cutting function for recorded transport streams. It is thus possible to automatically replay specific sections of long recordings in a loop or store them to a hard disk for further analysis or simple transfer to other instruments.

Stream Combiner™

Stream Combiner™ enables easy expansion of the transport stream library that is supplied. New transport streams can be quickly generated from supplied or recorded elementary streams. Used as an offline multiplexer, Stream Combiner™ automatically integrates all program information, service and system tables (PSI/SI/PSIP) required in accordance with MPEG-2 and the selected standard (ATSC or DVB).

In addition, Stream Combiner™ allows the user to edit, add to or remove all table contents – even in violation of standards – in order to generate test signals for specialized tasks. The transport stream files can be generated in GTS or TRP format. A separate data sheet is available for this option (PD 0757.3611).

Bit rates and memory

In the default state, transport streams (GTS format) are generated from RAM. They can be generated by inserting null packets at data rates up to 214 Mbit/s.

The R&S®DVM 400-B3 option additionally supports recording and replaying in TRP format at data rates up to 90 Mbit/s (TRP format).

The R&S®DVM 400-B4 option permits recording and replaying at up to 214 Mbit/s. Furthermore, this option doubles the available storage capacity for transport stream data from min. 80 Gbyte to min. 160 Gbyte.

How to generate a transport stream in a seamless endless loop

Transport streams can be seamlessly generated in an endless loop (GTS mode), provided the following two conditions are met:

- ◆ All time stamps (PCR, PTS and DTS values and entries in the TDT, TOT and STT tables) in the transport stream must be updated in realtime
- ◆ The individual elementary streams must be calculated or cut in such a way that they end with a complete GOP (video) or an entire frame (audio) so that no errors occur in the decoder; plus, they must be calculated in such a way that the average buffer fill state remains constant during a loop period to avoid any buffer underflow or overflow during continuous replay in an endless loop

If these conditions are met, the transport stream appears to be continuously generated in realtime directly from a multiplexer and a number of encoders connected to it, although the video, audio and data contents are repeated.

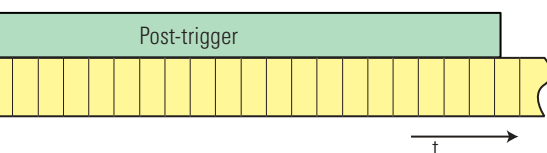

400 for triggered recording

Overview of options and functions

Base unit

Base unit	R&S®DVM 400	<ul style="list-style-type: none"> – computer platform <li style="padding-left: 20px;">motherboard <li style="padding-left: 20px;">hard disk <li style="padding-left: 20px;">RAM <li style="padding-left: 20px;">Windows XP Embedded – colour display – loudspeaker – keys and rotary knob – USB wheel mouse – 3 slots – 2 SPI connectors (input and output) – 10 MHz reference input – 12 alarm lines²⁾ – trigger input – Ethernet interface – 4 × USB connectors – expansion connector for R&S®DVM 120
------------------	-------------	--

Analyzer functions

Analyzer	R&S®DVM 400-B1	<ul style="list-style-type: none"> – analyzer board (4 ASI/310M connectors) – unblocking function for one transport stream (TS Input) – monitoring functions – analysis functions: in-depth analysis – event navigator – assistant
Additional TS Input	R&S®DVM-K1	– unblocking function for parallel monitoring of one additional transport stream
TS Capture	R&S®DVM-K2	– storage and recording of transport stream sections
Data Broadcast Analysis	R&S®DVM-K11	– analysis of data broadcast services

Recorder and generator functions

TS Generator (GTS format only)	R&S®DVM 400-B2	<ul style="list-style-type: none"> – generator board (ASI/310M connectors) – support of GTS mode – transport stream generation – test signal library
Upgrade TS Recorder TRP 90 Mbit/s (option R&S®DVM 400-B2 required)	R&S®DVM 400-B3	<ul style="list-style-type: none"> – hard disk – recording, replaying – bit rates up to 90 Mbit/s (hard disk) and 214 Mbit/s (memory)
Upgrade TS Recorder TRP 214 Mbit/s (options R&S®DVM 400-B2 and R&S®DVM 400-B3 required)	R&S®DVM 400-B4	<ul style="list-style-type: none"> – bit rates up to 214 Mbit/s (hard disk and memory) – doubling of hard disk memory (additional hard disk)
Test Card M Streams	R&S®DV-TCM	– additional test signals
HDTV Sequences	R&S®DV-HDTV	– additional test signals
Stream Combiner™	R&S®DVG-B1	<ul style="list-style-type: none"> – offline TS multiplexer software – elementary stream library

²⁾ If the trigger input is used for the TS recorder, only 11 alarm lines are available.

Abbreviations

AIT	Application information table
ATSC	Advanced Television Systems Committee
BAT	Bouquet association table
BIOP	Broadcast inter ORB protocol
CAT	Conditional access table
CETT	Channel extended text table
CVCT	Cable virtual channel table
DDB	Download data block
DIT	Discontinuity information table
DSI	Download server initiate
DII	Download info indication
DSM-CC	Digital storage media – command and control
DTS	Decoding time table
DVB	Digital video broadcast
EIT	Event information table
EPG	Electronic program guide
ETT	Extended text table
GOP	Group of picture
HDTV	High definition television
ID	Identifier
INT	IP/MAC notification table
IP	Internet protocol
IRD	Integrated receiver decoder
MAC	Media access control
MGT	Master guide table
MHP	Multimedia home platform
MIP	Megaframe initialization packet
MEPG	Motion Picture Expert Group
NIT	Network information table
ORB	Object request broker
PAT	Program association table
PCR	Program clock reference
PES	Packetized elementary stream
PID	Packet identification
PIT	Program identification table
PMT	Program map table
PSI	Program specific information
PSIP	Program and system information protocol
PT	Private table
PTS	Presentation time stamp
RRT	Rating region table
RST	Running status table
SDI	Serial digital interface
SDT	Service description table
SDTI	Serial digital transport stream interface
SI	Service information
SIT	Selection information table
ST	Stuffing table
SSU	System software update
STB	Set-top box
STT	System time table
TDT	Time and date table
TOT	Time offset table
TS	Transport stream
TVCT	Terrestrial virtual channel table
UNT	System software update notification table
VPS	Video programming system
WSS	Wide screen signalling

Specifications

R&S®DVM 400 base unit

PC platform/controller	
Operating system	Windows XP Embedded, service pack 1
RAM	256 Mbyte
System hard disk	IDE hard disk
Software	only software approved by Rohde & Schwarz for the R&S®DVM 400
USB interfaces	2 × USB1.1 on both the front and rear panels
Ethernet	
Remote control	10/100 Mbit/s; RJ-45
Control of local analyzer board	10/100 Mbit/s; RJ-45 max. 5 analyzer boards
External monitor	up to 1600 × 1200 pixels, min. 1024 × 768 pixels required 15-pin sub-D female connector for SVGA or TFT monitor
Alarm relays	12 ³⁾ with random event assignment; 15-pin sub-D female connector
Reference clock input	10 MHz, 0.1 V to 2 V (rms) BNC female connector on rear panel of base unit for analyzer board and recorder and generator board
General data	
Operating temperature range	+5 °C to +40 °C
Permissible temperature range	+5 °C to +40 °C
Storage temperature range	−40 °C to +70 °C
Mechanical resistance	
Vibration, sinusoidal	5 Hz to 150 Hz, max. 2 g at 55 Hz, 55 Hz to 150 Hz, max. 0.5 g const., meets DIN EN 60068-2-6, DIN EN 61000-1 and MIL-T-28800D class 5
Vibration, random	10 Hz to 300 Hz, acceleration 1.2 g (rms)
Shock	40 g shock spektrum, meets MIL-STD-810D and MIL-T-28800D class 3 und 5
Climatic resistance	95% rel. humidity, cyclic test at +25 °C/+40 °C, meets DIN EN 60068-2-30
Electromagnetic compatibility	meets EN 50081-1 and EN 50082-2 (EMC directive of EU)
Power supply	88 V to 264 V/47 Hz to 63 Hz
Dimensions (W × H × D)	375 mm × 176 mm × 285 mm
Weight	
With analyzer	7.8 kg
With recorder and generator	7.6 kg
With analyzer and recorder and generator	8.4 kg

Analyzer board

Signal inputs MPEG-2 transport stream ⁴⁾	
Serial inputs	4 inputs, each with BNC female connector (75 Ω)
	Selectable: asynchronous serial interface (ASI, according to DVB-A010) data rate: 270 Mbit/s mode: continuous or packet TS packets with 188/204/208 bytes
Or	synchronous serial input (SSI, according to SMPTE 310-M) data rate: 19.392658 Mbit/s TS packets with 188 bytes max. cable length 180 m
Parallel input	synchronous parallel interface (SPI, according to EN 50083-9) 25-pin female connector on front panel of base unit LVDS level
Maximum data rate across all inputs (max. 4)	214 Mbit/s ⁵⁾
Loop-through outputs MPEG-2 transport stream	inputs 2 and 4 selectable as loop-through output for input 1 and input 3

³⁾ If the trigger input is used for the TS recorder, only 11 alarm lines are available.

⁴⁾ The number of inputs that can be used simultaneously depends on the number of installed R&S®DVM-K1 options.

⁵⁾ Content-dependent.

Recorder and generator board

Signal inputs MPEG-2 transport stream	
Serial inputs	2 inputs, each with BNC female connector (75 Ω)
Selectable:	synchronous serial interface (ASI, according to DVB-A010) data rate: 270 Mbit/s mode: continuous or packet TS packets with 188/204/208 bytes
Or	synchronous serial input (SSI, according to SMPTE 310-M) data rate: 19.392658 Mbit/s TS packets with 188 bytes max. cable length 180 m
Parallel input	synchronous parallel interface (SPI, according to EN 50083-9) 25-pin female connector on front panel of base unit
Level: LVDS Clock: 84.375 kHz to 20 MHz Mode: TRP, 8 bit (8 bits data) T10, 10 bit (8 bits data, 1 bit data valid, 1 bit packet sync)	
Signal outputs MPEG-2 transport stream	
Serial outputs	2 outputs, each with BNC female connector (75 Ω)
Selectable:	asynchronous serial interface (ASI, according to DVB-A010) data rate: 270 Mbit/s mode: continuous or packet TS packets with 188/204/208 bytes
Or:	synchronous serial input (SSI, according to SMPTE 310-M) data rate: 19.392658 Mbit/s TS packets mit 188 bytes max. cable length 180 m
Parallel output	synchronous parallel interface (SPI, according to EN 50083-9) 25-pin female connector on rear panel of base unit
Level: LVDS Clock: 84.375 kHz to 20 MHz Mode: TRP, 8 bit (8 bits data) 1 bit packet sync automatically generated and 1 bit data valid configurable: – exactly 188 bytes active – constantly active with packet length of 204 or 208 bytes T10, 10 bit (8 bits data, 1 bit data valid, 1 bit packet sync)	
Loop-through outputs MPEG-2 transport stream	2 serial loop-through outputs ASI, according to DVB-A010 or SSI, according to SMPTE 310-M depending on signals at serial inputs

Signal characteristics	
TS generator (GTS format)	for generating transport streams according to ISO/ICE 1-13818 interface outputs: ASI, SPI and SS
Length of transport stream packets	ATSC: 188/208 bytes (selectable) DVB: 188/204 bytes (selectable)
Sequence length: endless and seamless generation with repetition of video, audio and data contents Data rate: 675 kbit/s to 214 Mbit/s (including null packets) Net data rate: max. 90 Mbit/s Data volume: max. 80 Mbyte payload PCR jitter form: sine, rectangle and triangle frequency: 1 mHz to 100 kHz amplitude: 0 ms to 1 ms, increment 0.1 μ s Signal set: moving picture sequences and test patterns with test tones, for 625 and 525 lines Systems: DVB/ATSC Additional signals via options	
Generator (TRP format) and recorder 90 Mbit/s with option R&S®DVM 400-B3	(8 bit) for recording and replaying signals of any content interface inputs and outputs: ASI, SPI and SSI (10 bit) for recording and replaying signals of any content interface inputs and outputs: SPI
Min. data rate: 675 kbit/s Max. data rate: 214 Mbit/s from memory 90 Mbit/s from hard disk Max. data volume limited only by size of hard disk Endless replay, packet-exact cut at transition from end of file to beginning of file	
Generator (TRP format) and recorder 214 Mbit/s with options R&S®DVM 400-B3 and R&S®DVM 400-B4	(8 bit) for recording and replaying signals of any content interface inputs and outputs: ASI, SPI and SSI (10 bit) for recording and replaying signals of any content interface inputs and outputs: SPI min. data rate: 675 kbit/s max. data rate: 214 Mbit/s from memory and hard disk max. data volume limited only by size of hard disk endless replay, packet-exact cut at transition from end of file to beginning of file

Ordering information

Designation	Type	Order No.
Base unit		
Digital Video Measurement System	R&S® DVM 400	2085.1800.02
Analyzer options		
Analyzer	R&S® DVM 400-B1	2085.5505.02
Additional TS Input	R&S® DVM-K1	2085.5211.02
TS Capture ⁶⁾	R&S® DVM-K2	2085.5234.02
Data Broadcast Analysis	R&S® DVM-K11	2085.5311.02
Recorder and generator options⁶⁾		
TS Generator (GTS format only)	R&S® DVM 400-B2	2085.5511.02
Upgrade TS Recorder up to 90 Mbit/s	R&S® DVM 400-B3	2085.5528.02
Upgrade TS Recorder up to 214 Mbit/s	R&S® DVM 400-B4	2085.5534.02
Test Card M Streams	R&S® DV-TCM	2085.7708.02
HDTV Sequences	R&S® DV-HDTV	2085.7650.02
Stream Combiner™	R&S® DVG-B1	2068.9835.02
Recommended extras		
Documentation of Calibration Values	R&S® DVM-DCV	2082.0490.29
Service Manual		2085.1839.02

⁶⁾ Available on request.

More information at
www.rohde-schwarz.com
 (search term: DVM400)



ROHDE & SCHWARZ

www.rohde-schwarz.com